

VALVULA ESCLUSA H° D° P/PVC

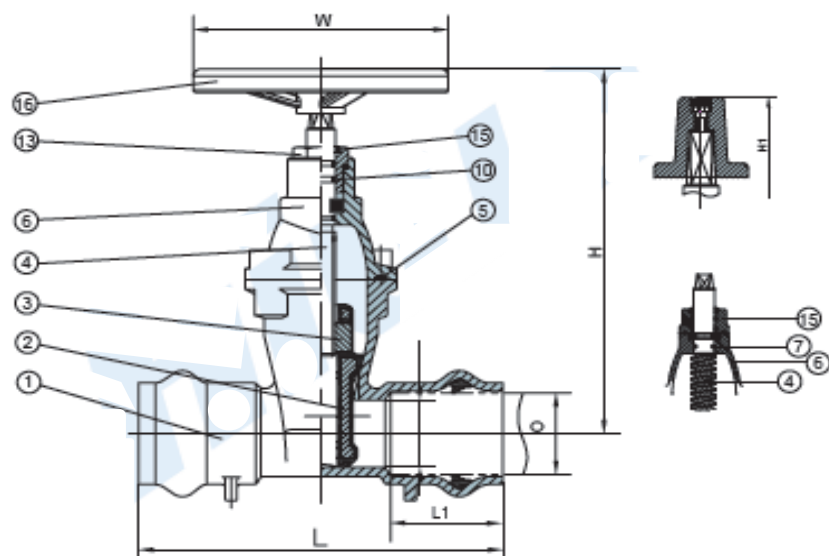

▲ MATERIAL SPECIFICATION

Item	Part Name	Material	Item	Part Name	Material
1	Body	GGG50	8	Bonnet	GGG50
2	Wedge	DI+EPDM/NBR	7	Back Sealing O Ring	EPDM/NBR
3	Wedge Nut	Brass	13	Stuffing Nut	Brass
4	Stem	AISI 420	15	Gland Flange	GGG50
10	O-Ring	EPDM/ NBR			

▲ DIMENSIONS (mm)

Size	PIPE DIA. O	L		L1	H	H1	W	W.T(kg)	
		F5	SABS					F5	SABS
DN50	63	250	335	77	300	340	180	7.15	9.5
DN65	75	270	335	80	310	350	180	8.25	10.5
DN80	90	280	335	84	350	390	200	12.65	15
DN100	110	300	355	88	380	420	220	18.7	21
DN125	125	325	375	91	420	460	220	23.1	27.5
DN125	140	325	375	91	420	460	220	24.2	28
DN150	160	350	405	94	470	510	250	33	38
DN200	200	400	450	100	590	630	280	45.1	50
DN200	225	400	450	100	590	630	280	47.3	55
DN250	250	450	450	125	680	720	320	67.1	67.1
DN300	315	500	500	140	790	830	360	92.4	92.4

Características

- * Bajo Torque
- * Cuña de goma encapsulada
- * Dirección de cierre hacia la izquierda
- * Epoxy en el interior revestido
- * Máxima temperatura 80 ° C

Especificaciones Técnicas

- * Pruebas hidráulicas ISO 5208
- * Presion de prueba en el ASIENTO: 17,6 bar
- * Presion de prueba en el cuerpo: 24 bar